

Equipment details

Customer: IMC Diving AS
 Producer: Kirby Morgan
 Serial no: 15078SS
 Service interval: 12 months

Location: 138
 Model: 97
 Build year:

Regulator Serial Number / Model:

1. Neck Ring / Helmet Attachment + Hood Assembly

Neck dam removed and inspected for wear, tears or damage. Replace if damaged. Pass

Chin strap and fasteners inspected for wear or damage. Clean or replace as required. Pass

Neck ring O-ring removed, groove cleaned, neck ring inspected, new O-ring installed. Pass

Sealed pull pins removed, cleaned, inspected for oil leakage and smooth operation. Service if required. Pass

Comment: Byttet pull pin grunnet stor slitasje

Locking collar disassembled, cleaned and inspected. Components replaced as required. Lock nut replaced. Pass

2. Helmet / Mask Assembly

Removed regulator pod?: (not set)

Water dump body removed?: (not set)

Helmet liner and cushion removed and inspected. Foam, liner and snaps checked and serviced. Pass

Earphones and microphone removed and inspected. Communications check performed. Pass

Communications module and auxiliary port removed, cleaned and O-rings replaced. Pass

Helmet shell inspected for cracks, gouges, exposed fiberglass or damage. Pass

Nose block device removed, cleaned and inspected. O-rings replaced. Pass

Oral nasal mask and valve assembly removed, cleaned and inspected. Valve replaced and reinstalled. Pass

Bent tube removed. O-rings replaced at side block and regulator ends. Bent tube replaced if damaged. Pass

Demand regulator, whiskers and exhaust body removed as one unit. Pass

Exhaust system disassembled, cleaned and inspected. Rubber parts replaced if required. Pass

Exhaust valves replaced. Pass

Front stand-offs removed, cleaned and inspected if fitted. Pass

Swing tongue catch disassembled, cleaned, inspected and reassembled. Pass

Face port retainer, face port and O-ring removed and inspected. Pass

View port insert pull test performed (fiberglass helmets only). O-ring replaced. Pass

Regulator pod cleaned and serviced (stainless steel helmets only). Pass

Main exhaust/dewatering valve replaced and seating surface inspected. Pass



3. Side Block

Side Block removed?: Yes

One-way valve removed, disassembled and overhauled. **Pass**

Umbilical adapter removed and replaced with new. **Pass**

Emergency valve and steady flow valve removed, overhauled and O-rings replaced. **Pass**

4. Demand Regulator

Demand regulator disassembled and inspected for corrosion or contamination. **Pass**

All parts cleaned. All O-rings and inlet valve seat replaced. **Pass**

Demand regulator reassembled. **Pass**

Adjustment shaft checked for smooth movement and no binding. **Pass**

Exhaust main body and whiskers installed on regulator. **Pass**

Regulator mounted in helmet. **Pass**

Bent tube installed with new Teflon washer and O-ring. **Pass**

Oral nasal mask valve assembly and nose block device reinstalled. **Pass**

Demand regulator tested and fine-tuned for proper operation. **Pass**

Port Insert Test Sheet (A2.1)

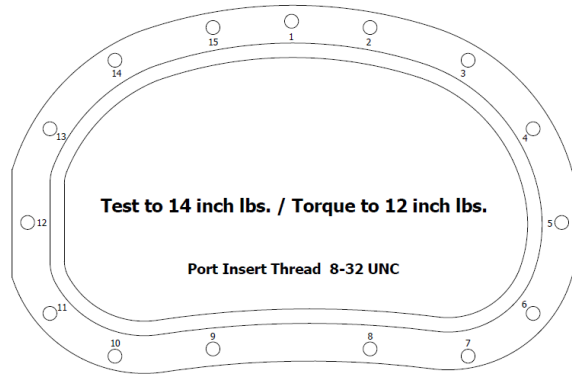

Test Results (P=Pass, F=Fail)

Port insert 1	Pass	Port insert 9	Pass
Port insert 2	Pass	Port insert 10	Pass
Port insert 3	Pass	Port insert 11	Pass
Port insert 4	Pass	Port insert 12	Pass
Port insert 5	Pass	Port insert 13	Pass
Port insert 6	Pass	Port insert 14	Pass
Port insert 7	Pass	Port insert 15	Pass
Port insert 8	Pass		

Technician

Serviced by: Thomas Eriksson

Technical addendum (Sections 1-4)

1. General Notes on the Neck Ring Assembly and Helmet Attachment Components

Although most neck ring and neck dam components across various Kirby Morgan helmet models are identical or very similar, all service must always be performed according to the specific manual for the helmet model being serviced. This ensures that any model-specific differences in assembly methods, material specifications, or procedures are correctly followed.

Furthermore, it must be emphasized that all KM helmets must be equipped with an internal chin strap, which serves as a secondary retention system in the event the helmet should separate from the neck ring. While the inspection of this strap is included in the checklist, its functional importance warrants explicit mention here.

Sealed pull pins are factory-filled with silicone oil. The presence of oil outside the pin, or reduced smoothness of operation, may indicate internal leakage. Servicing of these components should only be performed by personnel who have received proper manufacturer-approved training, as incorrect handling may compromise the safety integrity of the helmet.

Metal components of the helmet must also be carefully inspected for corrosion, including discoloration, pitting, or microscopic cracks, as such damage can lead to sudden material failure without prior warning.

2. Notes on the Helmet Assembly Inspection

When inspecting the helmet shell, it is important to remove all non-KMDSI factory stickers. This is particularly critical on fiberglass helmets, where incomplete inspection of the gelcoat and underlying structure may allow hidden damage to go unnoticed.

On fiberglass helmets, any damage that penetrates through the gelcoat into the fiberglass layer must be repaired immediately by a certified technician. Deep damage (1.5 mm or more) must be evaluated by a KMDSI/Dive Lab-certified professional, and shell repairs may only be performed by personnel specifically authorized for helmet shell repair.

When handling the oral-nasal mask, it is essential that the nose block device is removed before the mask is removed or installed. Attempting to stretch the mask over the nose block will almost certainly result in tearing of the rubber.

The exhaust system must be assessed as a complete assembly, and even minor signs of rubber degradation are sufficient cause for immediate replacement. This includes small cracks, hardening, or early signs of material fatigue.

For stainless steel helmets equipped with a regulator pod, the pod does not need to be removed every year unless there are visible signs of internal corrosion. However, full removal, overhaul, and reinstallation is recommended at least every three years to ensure that hidden corrosion is identified before it becomes critical.

3. Additional Notes on the Side Block Inspection

The side block does not necessarily need to be removed every year, provided there are no signs of internal corrosion in its passages or valve components. However, all valves—one-way valve, emergency valve, and steady-flow valve—must be overhauled and fitted with new O-rings at least once per year. This ensures correct performance under pressure and maintains a reliable safety margin.

It is also emphasized that the umbilical adapter must always be replaced with a new one during the annual service, regardless of its apparent condition. This component is exposed to mechanical stress and may develop microscopic deformation over time.

4. Notes Regarding the Demand Regulator

Although the checklist covers disassembly and replacement of soft goods in the regulator, it is important to clarify that regulator adjustment must only be performed after full disassembly and correct reassembly. The regulator cover must be assessed not only for visible damage but also for deformation of the airflow slots, as these are critical for proper regulator performance.

Any damage or wear in the purge button travel area is sufficient reason to replace the regulator cover. Older covers that have become thin, wavy, or show signs of material fatigue must also be replaced, even if no obvious damage is present.

The inlet valve adjustment lock nut on SuperFlow models must never be reused. While this is mentioned in the checklist, the significance of this requirement cannot be overstated: reusing the lock nut can cause the regulator to drift out of adjustment, leading to unpredictable breathing resistance during use.

Finally, the regulator must undergo a full functional test after reassembly, including fine-tuning of breathing resistance and verification that the adjustment shaft moves freely and smoothly.